

Dental Sensor

USER MANUAL

Changzhou Sifary Medical Technology Co., Ltd.

Version: S02
IFU-6935025
Issued: 2024.04.24
Size: 130mm x 184mm

Table of Contents







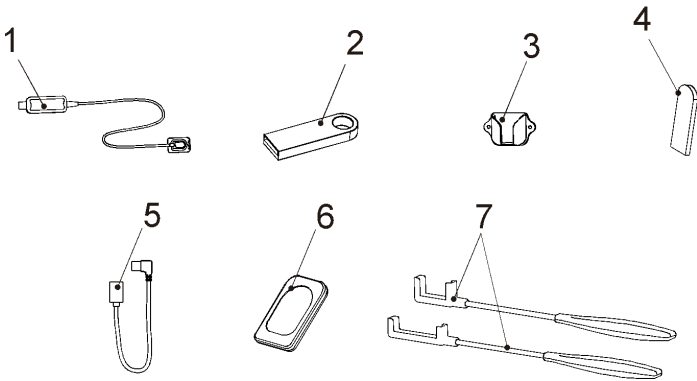









1. Scope of Sensor	4
2. Symbols	5
3. Introduction	7
3.1 Scope of Application	7
3.2 Contraindications	7
3.3 Safety Instructions	7
4. Product Installing	9
4.1 Installation Environment Requirements	9
4.2 Cybersecurity	9
4.3 Connecting the Sensor to the Computer Terminal.	10
4.4 Software Installing	11
4.5 Software Update	14
4.6 Sensor Mounting	14
4.7 Sensor Protection	14
4.8 Use of Handheld Bracket	15
5. Software Introduction	17
5.1 Login	17
5.2 Software Interface Introduction	18
5.3 The Menu of Tools	19
5.4 Patient Medical Record Menu	22
5.5 Oral X-ray Image Acquisition Menu	24
5.6 Oral X-ray Image View Menu	27
5.7 Oral Diagnostic Report Menu	30
6. Operating Instructions	32
6.1 Acquiring Oral X-ray Image	32
6.2 Importing Existing Oral X-ray Images	36
6.3 Image Quality Optimization	38
6.4 Report Generation	38
7. Recommended X-ray Source Parameters and Exposure Time	41
7.1 Compatibility with radiographic generators	41
7.2 Recommendation	41
8. Maintenance	44
8.1 Foreword	44
8.2 General recommendations	44
8.3 Disinfection components	45
8.4 Autoclavable Components	46
8.5 Sensor inspection	50
9. Troubleshooting	52
10. Technical Data	54
11. EMC Tables	55
12. Statement	60

1. Scope of Sensor



1. Sensor
2. USB Flash Driver
3. Sensor Mounting Bracket
4. Disposable Sleeve
5. USB Extension Cable
6. Silicone Protective Cover
7. Handheld Bracket (Optional).



2. Symbols

 WARNING	If the instructions are not followed properly, the operation may lead to hazards for the product or the user/patient.
 NOTE	Additional information, explanation of operation, and performance.
	Serial number
	Catalogue number
	Manufacturer
	Date of manufacture
	Lot of manufacture
	Type BF applied part
	Dispose of in accordance with the WEEE directive
	Keep dry
	Temperature limitation
	Humidity limitation
	Atmospheric pressure limitation
	Manufacturer's LOGO
	Follow instructions for use
	Do not reuse
IP68	Protection against liquid and particular matter
IPX8	Protection against liquid

2 Symbols

Rx only	Federal law restricts the sale of this device by or on the order of a dentist
	Medical device
	Washer-disinfector for thermal disinfection
	Sterilizable in a steam sterilizer (autoclave) at the temperature specified

3. Introduction

3.1 Scope of Application

Dental Sensors, models NanoPix1, NanoPix1.5 and NanoPix2 are intended to collect dental x-ray photons and convert them into electronic impulses that may be stored, viewed, and manipulated for diagnostic use by dentists. This device must only be used in hospital environments, clinics or dental offices by trained and qualified dental personnel, and not used in the oxygenrich environment.

This device is suitable for providing dental radiography imaging for both adult and pediatric.

3.2 Contraindications

Patients and operators of cardiac pacemakers, and pregnant women should use the device with caution.

3.3 Safety Instructions

1. Please read this manual before use.
2. The safety regulations and guidelines of NanoPix1/ NanoPix1.5/NanoPix2 must be installed and used following the purposes specified in the manual.
3. Do not use the device when the sensor is damaged.
4. Avoiding liquid entering the device, which could cause short circuit or corrosion.
5. This device must be disconnected from the power supply before cleaning or disinfection.
6. To avoid the cross-infection of patients, a disposable sleeve must be used before placing the sensor in the mouth, and the sleeve must be discarded after use on each patient.



WARNING

Please read the following warning carefully before using:

1. This device can only be used by people with relevant qualifications and technical approval.
2. The device must not be placed in humid surroundings or anywhere where it can come into contact with any type of liquids.
3. Do not expose the device to direct or indirect heat sources. The device must be operated and stored in a safe environment.
4. The device requires special precautions concerning electromagnetic compatibility (EMC) and must be installed and operated in strict compliance with the EMC information. In particular, do not use the device in the vicinity of fluorescent lamps, radio transmitters, remote controls and do not use this system near the active HF Surgical Equipment in the hospital. Portable RF communications equipment (including peripherals such as antenna cables and external antennas) should be used no closer than 30 cm (12 inches) to any part of the NanoPix1/ NanoPix1.5/NanoPix2, including cables specified by the manufacturer. Otherwise, degradation of the performance of this equipment could result.
5. Do not operate or store at high temperatures.
6. If irregularities occur in the device during treatment, switch it off. contact the agency.
7. Never open or repair the device yourself, otherwise, void the warranty.
8. Please use original accessories and install original software.

4. Product Installing

4.1 Installation Environment Requirements

Since this product is not equipped with a computer, during the installation of this product, customers need to provide an additional laptop or desktop computer. The specific performance requirements of the computer are as follows:

1. Hardware requirements

CPU	$\geq 1.0\text{GHz}$
Memory	$\geq 2\text{GB}$
Hard Disk	$\geq 64\text{GB}$
Display Resolution	1024*768 or above
USB ports	USB2.0 ≥ 1

2. Operating system requirements

- Microsoft Windows 7/8/10 32-bit/64-bit

4.2 Cybersecurity

1. No Network: NanoPix do not need to connect to the network during use. Please make sure that the NanoPix installation environment is safe or install security software in the installation environment to avoid dangers related to cybersecurity.

2. Data Interface and Transfer Protocol: USB2.0

3. Data Format: JPG, PNG, BMP, DICOM

4. User Access Control:

Account Setting: NanoPix software adopts account settings when starting, and users can open the software only after entering the correct user name and password.

Encryption and Binding: NanoPix is encrypted and bound with Dental Sensor.

Only when the license file and sensor calibration file are included, the user can use the software normally.

4.3 Connecting the Sensor to the Computer Terminal.

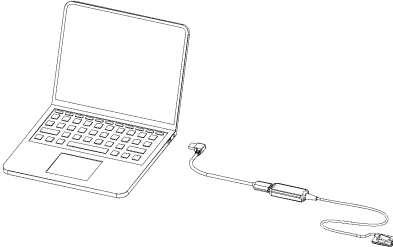
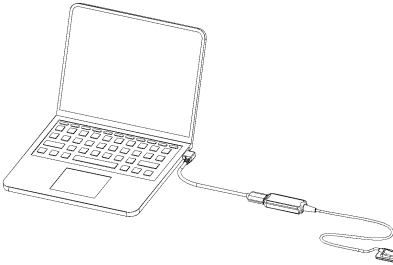
Step	Graphic Example	Description
1		<p>Connect the USB extension cable and the sensor, and then insert the other end of the USB extension cable into USB sockets on the computer.</p>
2		<p>Check and ensure the connection between the computer and the sensor is reliable.</p>



All IT components electrically connected to the NanoPix1/NanoPix1.5/NanoPix2 must confirm to IEC 60950-1.

4.4 Software Installing

Make sure the sensor is connected to the computer terminal before installing the software.

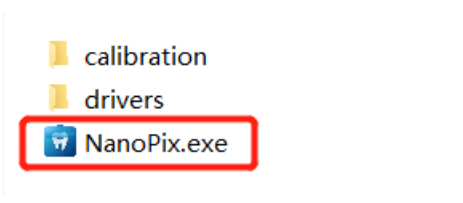
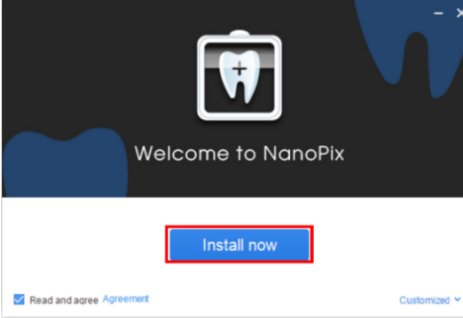
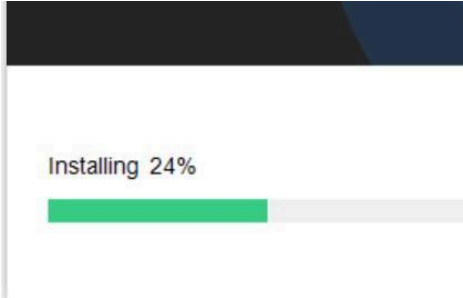
<p>Step 1:</p> <p>Connect the USB flash driver to the computer and open it.</p>	
<p>Step 2:</p> <p>double click .exe file, and then click</p> <p>Install now</p>	
<p>Step 3:</p> <p>Enter the software installation, wait for the software to pop up the driver installation dialog box.</p>	

4. Product Installing

Step 4:

The software pops up the driver installation dialog box, and click

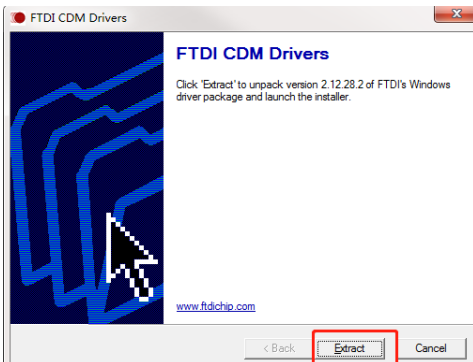
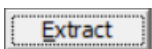

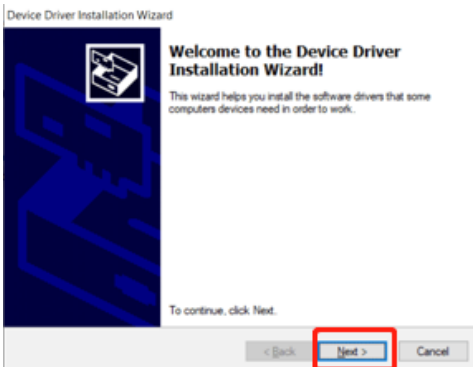
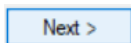

Step 5:

Click

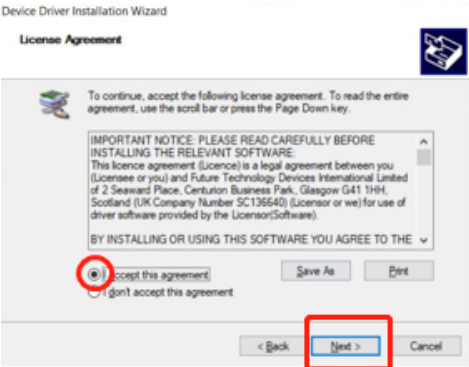
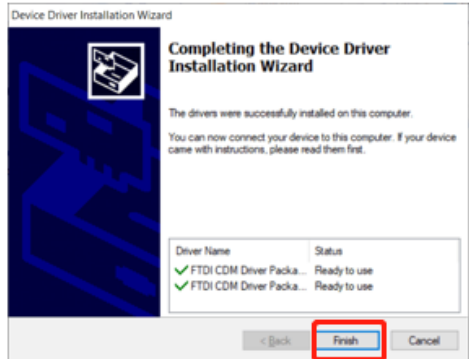

4. Product Installing

<p>Step 6:</p> <p>Accept the agreement to continue to the next step.</p>	 <p>Device Driver Installation Wizard</p> <p>License Agreement</p> <p>To continue, accept the following license agreement. To read the entire agreement, use the scroll bar or press the Page Down key.</p> <p>IMPORTANT NOTICE: PLEASE READ CAREFULLY BEFORE INSTALLING THE RELEVANT SOFTWARE. This license agreement (License) is a legal agreement between you (Licensee or you) and Future Technology Devices International Limited of 2 Seaward Place, Certunton Business Park, Glasgow G41 1HH, Scotland (UK Company Number SC136640) (Licensor or we) for use of driver software provided by the Licensor/Software.</p> <p>BY INSTALLING OR USING THIS SOFTWARE YOU AGREE TO THE</p> <p><input checked="" type="radio"/> I accept this agreement <input type="radio"/> I don't accept this agreement</p> <p>Save As Print</p> <p>< Back Next > Cancel</p>						
<p>Step 7:</p> <p>The software pops up a dialog box on the right, click Finish, to indicate successful driver installation.</p>	 <p>Device Driver Installation Wizard</p> <p>Completing the Device Driver Installation Wizard</p> <p>The drivers were successfully installed on this computer.</p> <p>You can now connect your device to this computer. If your device came with instructions, please read them first.</p> <table border="1"><thead><tr><th>Driver Name</th><th>Status</th></tr></thead><tbody><tr><td>✓ FTDI CDM Driver Packa...</td><td>Ready to use</td></tr><tr><td>✓ FTDI CDM Driver Packa...</td><td>Ready to use</td></tr></tbody></table> <p>< Back Finish Cancel</p>	Driver Name	Status	✓ FTDI CDM Driver Packa...	Ready to use	✓ FTDI CDM Driver Packa...	Ready to use
Driver Name	Status						
✓ FTDI CDM Driver Packa...	Ready to use						
✓ FTDI CDM Driver Packa...	Ready to use						

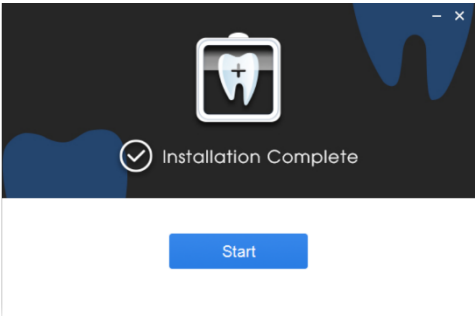
<p>Step 8:</p> <p>In the last step, the software installation successful dialog box pops up, you can click  or close it.</p>	
---	---

4.5 Software Update

If there is an update of NanoPix software, we(Sifary) will notify local distributors (agents) and provide free installation U disk, and the distributor(agent)s will upgrade the software for everyone.

4.6 Sensor Mounting

It is recommended to use the sensor mounting bracket to place the sensor. The installation method is as follows:

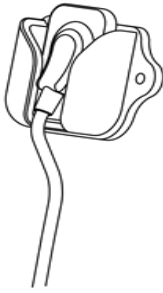

<ol style="list-style-type: none">1. Use screws and vias to fix the sensor mounting bracket to the wall.	
--	--

4. Product Installing

<p>2. Place unused sensors in the mounting bracket.</p>	
---	---

4.7 Sensor Protection

When the sensor is not in use, it can be wrapped with a silicone protective cover, which has reduced scratches or wears on the sensor receiving board. The sensor silicone protective cover is used as follows:



<p>1. Prepare the sensor and the silicone protective cover</p>	
<p>2. Gently put the silicone protective cover on the sensor receiving board</p>	

4.8 Use of Handheld Bracket

When using the Dental Sensor system for intraoral imaging, it is recommended to use the sensor with the handheld bracket. The handheld bracket has 2 types for each model, **A** and **B**.

The use of **handheld bracket A**:

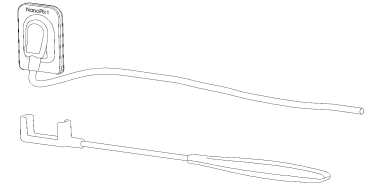
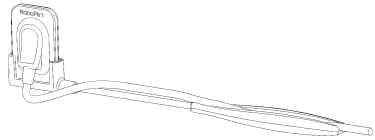
4. Product Installing

<p>1. Prepare the sensor and the handheld bracket A.</p>	
<p>2. Insert the long side of the sensor into the handheld bracket A in the vertical direction and fix the wire.</p>	
<p>3. Use a Disposable Sleeve to cover the sensor and handheld bracket A and then place it in the mouth for imaging.</p>	

The use of **handheld bracket B:**

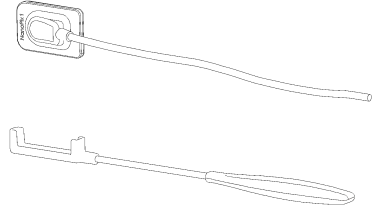
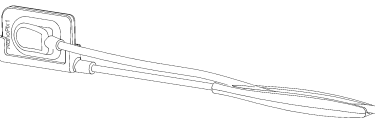
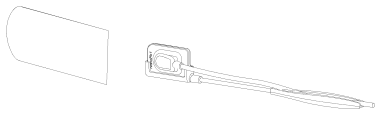
<p>1. Prepare the sensor and the handheld bracket B.</p>	
<p>2. Insert the short side of the sensor into the handheld bracket B in the vertical direction and fix the wire.</p>	
<p>3. Use a Disposable Sleeve to cover the sensor and handheld bracket B and then place it in the mouth for imaging.</p>	

5. Software Introduction

5.1 Login



Click the icon on the desktop to start the software, and its startup interface is as shown in the figure below:

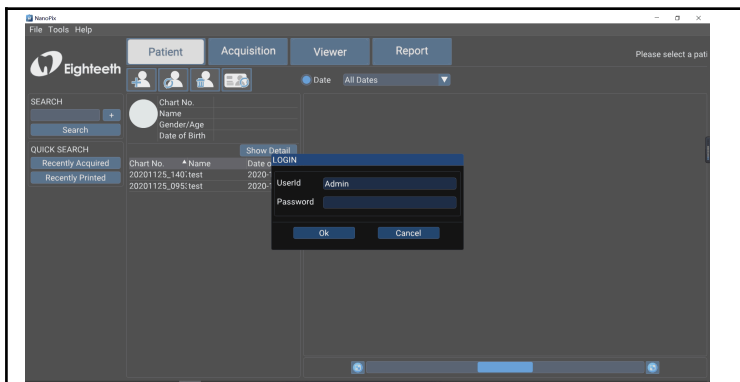

UserId	Admin(Default)
Password	123456(Default)

5.2 Software Interface Introduction

After completing the user login, the software enters the home page interface:

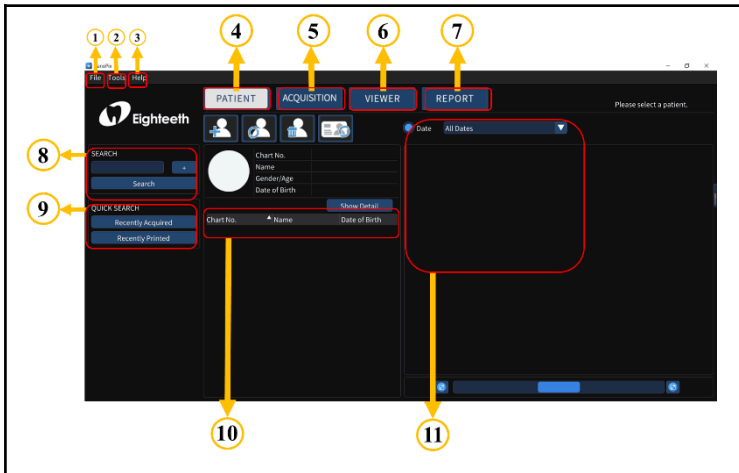

①	File: Use to exit.
②	Tools: Use for the basic setting of the software.
③	Help: User guides.
④	PATIENT: Patient Medical Record Menu.
⑤	ACQUISITION: Oral X-ray Image Acquisition Menu.
⑥	VIEWER: Oral X-ray Image View Menu.
⑦	REPORT: Oral Diagnostic Report Menu.
⑧	SEARCH: Use for searching for the diagnostic data in the software database. When the content of the search box is empty,

	clicking the search button could display all the diagnostic data in the database.
9	QUICK SEARCH: Use for searching for the recently acquired or recently viewed diagnostic data.
10	Medical record list display area.
11	Use for filtering medical records by date.





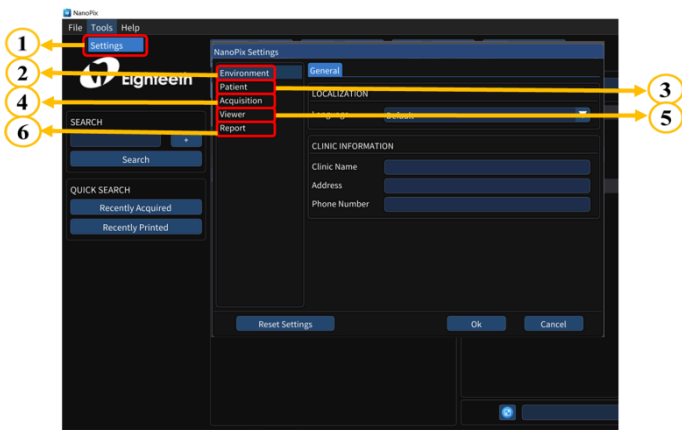

5.3 The Menu of Tools

The menu of Tools is used for the basic setting of the software

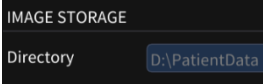
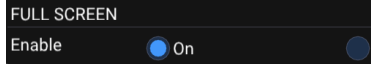
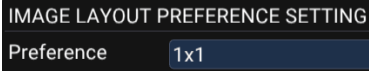

1	Setting: Use for basic setting of the software.			
2	<table border="1"> <tr> <td rowspan="2">Environment Setting</td> <td>Language <input type="text" value="Language"/> Language setting.</td> </tr> <tr> <td> USER STYLE Icon Size <input type="radio"/> Small <input checked="" type="radio"/> Medium <input type="radio"/> Big </td> </tr> </table>	Environment Setting	Language <input type="text" value="Language"/> Language setting.	USER STYLE Icon Size <input type="radio"/> Small <input checked="" type="radio"/> Medium <input type="radio"/> Big
Environment Setting	Language <input type="text" value="Language"/> Language setting.			
	USER STYLE Icon Size <input type="radio"/> Small <input checked="" type="radio"/> Medium <input type="radio"/> Big			





		<p>User Style Setting.</p> <p>Clinic Name Clinic Name setting.</p> <p>Address Address setting.</p> <p>Phone Number Phone Number setting</p>								
3	Patient Setting	<p>CHART NUMBER SETTING Chart Number setting</p> <p>PATIENT NAME OPTION Patient Name Option</p> <p>QUICK SEARCH Quick Search setting.</p>								
4	Acquisition Setting	<table border="1"> <tr> <td data-bbox="350 543 467 765"></td> <td data-bbox="467 543 872 765"> <p>TRIGGER SETTING</p> <p>Mode <input checked="" type="radio"/> DC <input type="radio"/></p> <p>Threshold 50uGy</p> <p>Trigger Mode and Threshold settings</p> <p>Threshold: 50uGy, 100uGy, 200uGy</p> </td> </tr> <tr> <td data-bbox="350 765 467 1148">General</td> <td data-bbox="467 765 872 1148"> <p>IMAGE PREFERENCE SETTING</p> <p>Preference Endodontic</p> <p>Image Preference:</p> <p>Endodontic; Periodontic; Restorative.</p> </td> </tr> <tr> <td data-bbox="350 1148 467 1324"></td> <td data-bbox="467 1148 872 1324"> <p>TEETH LAYOUT PREFERENCE SETTING</p> <p>Preference Adult</p> <p>Teeth Layout: Adult and Child.</p> </td> </tr> <tr> <td data-bbox="350 1148 467 1324">Image</td> <td data-bbox="467 1148 872 1324"> <p>IMAGE CALIBRATION</p> <p>IO Sensor 0.020</p> <p>Image Calibration: Use for the image resolution while displaying, keep the</p> </td> </tr> </table>		<p>TRIGGER SETTING</p> <p>Mode <input checked="" type="radio"/> DC <input type="radio"/></p> <p>Threshold 50uGy</p> <p>Trigger Mode and Threshold settings</p> <p>Threshold: 50uGy, 100uGy, 200uGy</p>	General	<p>IMAGE PREFERENCE SETTING</p> <p>Preference Endodontic</p> <p>Image Preference:</p> <p>Endodontic; Periodontic; Restorative.</p>		<p>TEETH LAYOUT PREFERENCE SETTING</p> <p>Preference Adult</p> <p>Teeth Layout: Adult and Child.</p>	Image	<p>IMAGE CALIBRATION</p> <p>IO Sensor 0.020</p> <p>Image Calibration: Use for the image resolution while displaying, keep the</p>
	<p>TRIGGER SETTING</p> <p>Mode <input checked="" type="radio"/> DC <input type="radio"/></p> <p>Threshold 50uGy</p> <p>Trigger Mode and Threshold settings</p> <p>Threshold: 50uGy, 100uGy, 200uGy</p>									
General	<p>IMAGE PREFERENCE SETTING</p> <p>Preference Endodontic</p> <p>Image Preference:</p> <p>Endodontic; Periodontic; Restorative.</p>									
	<p>TEETH LAYOUT PREFERENCE SETTING</p> <p>Preference Adult</p> <p>Teeth Layout: Adult and Child.</p>									
Image	<p>IMAGE CALIBRATION</p> <p>IO Sensor 0.020</p> <p>Image Calibration: Use for the image resolution while displaying, keep the</p>									

			<p>default value.</p>  <p>Image Storage path</p>
5	Viewer Setting	General	 <p>Full Screen setting: On and Off.</p>  <p>Image Lauout Preference Setting: 1x1, 1x2, 2x1 and 2x2.</p>
		Tools	 <p>Includes Magnifier size, Capture Border Color and Grid settings.</p>
		Mesur-a ment	 <p>Includes Length and Angle settings.</p>
		Annot-at ion	 <p>Includes Draw, Line, Rectangle and Ellipse settings.</p>
		Memo	 <p>Includes Memo Style and Text Preset settings.</p>
6	Report Setting	Print	 <p>Includes Paper, Header and Footer Preference settings.</p>

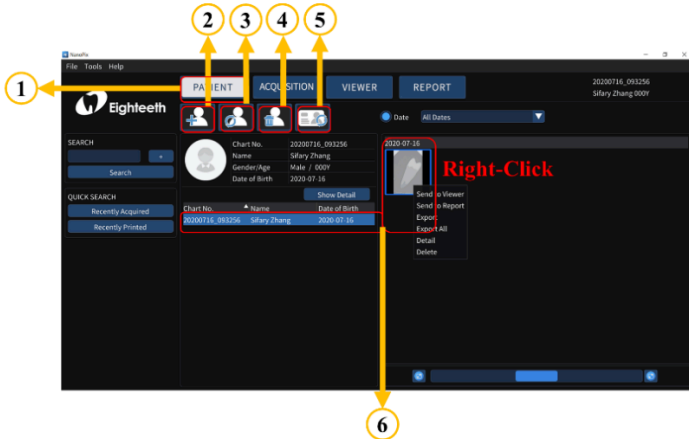
5.4 Patient Medical Record Menu

The main page of Patient Medical Record Menu



①	PATIENT: Click it and enter the Patient Medical Record interface.
②	 : Use to create a new medical record.
③	 : Use to edit a medical record.
④	 : Use to delete a medical record.
⑤	 : Use to clear the medical record list.

<p style="text-align: center;">6</p>	<p>Patient list and thumbnails of selected patients: Right-click the selected thumbnail to quickly execute :</p> <ol style="list-style-type: none">1. Send to the Viewer;2. Send to Report;3. Export;4. Export All;5. Detail;6. Delete.
---	---

5.5 Oral X-ray Image Acquisition Menu

The main page of Oral X-ray Image Acquisition Menu : IO Sensor

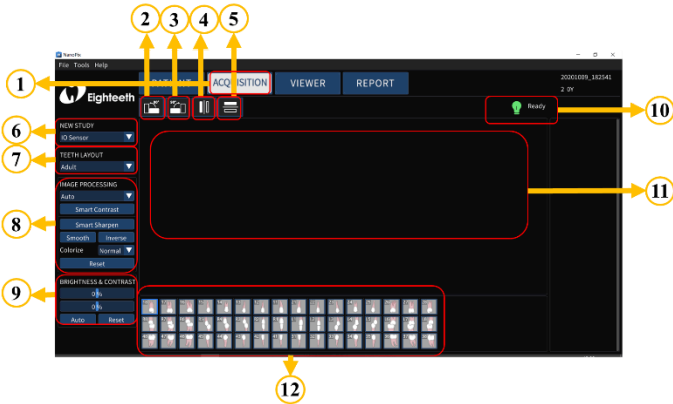

1 **ACQUISITION:** Click it and enter the oral X-ray Image Acquisition Menu interface.

2  **90CCW:** Use to rotate image 90° counterclockwise.

3  **90CW:** Use to rotate image 90° clockwise.

4  **Flip Horizontal:** Use to make image mirror left and right.

5  **Flip Vertical:** Use to make image mirror up and down.

NEW STUDY: represents the data source.

6 **IO Sensor:** data comes from the sensor;
Import: data comes from local.



7 **TEETH LAYOUT:** use to determine the age group: adult or child.

<p>8</p>	<p>IMAGE PROCESSING: use to process the acquired image data, include Endodontic, Periodontic, Restorative, Smart Contrast, Smart Sharpen, Smooth, Inverse, Colorize, and Reset.</p>
<p>9</p>	<p>BRIGHTNESS & CONTRAST: Manual, Auto and Reset.</p>
<p>10</p>	<p>Sensor Indicator: “Waiting Exposing”: Indicate that the sensor is connected successfully and can be exposed. “Offline”: Sensor is not connected.</p>
<p>11</p>	<p>The display area of the oral X-ray image.</p>
<p>12</p>	<p>Examples of different teeth layout.</p>

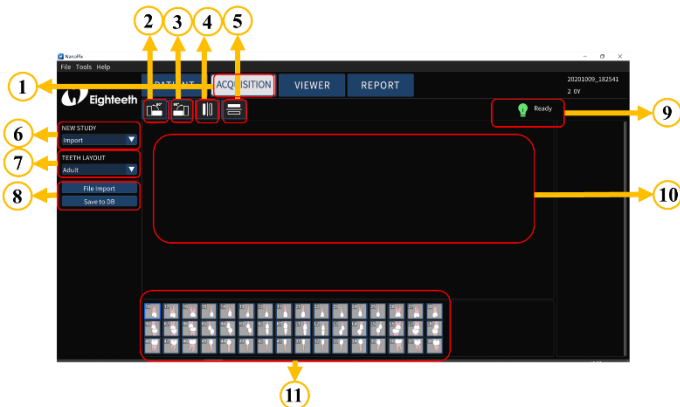
The main page of Oral X-ray Image Acquisition Menu: Import









<p>1</p>	<p>ACQUISITION: Click it and enter the oral X-ray Image Acquisition Menu interface.</p>
<p>2</p>	<p> 90CCW: Use to rotate image 90° counterclockwise.</p>

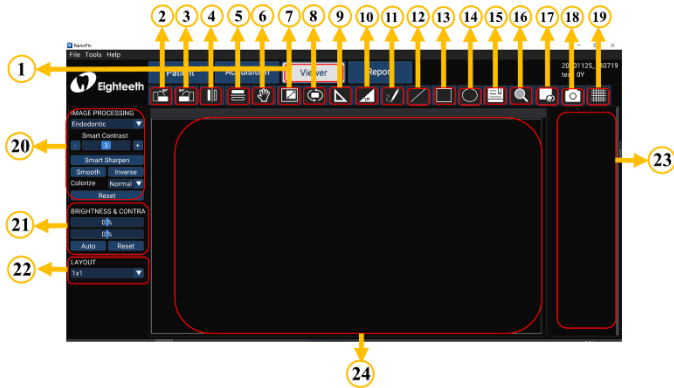









3	 90CW: Use to rotate image 90° clockwise.
4	 Flip Horizontal: Use to make image mirror left and right.
5	 Flip Vertical: Use to make image mirror up and down.
6	NEW STUDY: represents the data source. IO Sensor: data comes from the sensor; Import: data comes from local.
7	TEETH LAYOUT: use to determine the age group: adult or child.
8	File Import: import image data from local. Save to DB: save image data to the database.
9	/(No need to care).
10	The display area of the oral X-ray image.
11	Examples of different teeth layout.



5.6 Oral X-ray Image View Menu

The main page of Oral X-ray Image View Menu



①	VIEWER: Click it and enter the Oral X-ray image View Menu interface.
②	 90CCW: Use to rotate image 90° counterclockwise.
③	 90CW: Use to rotate image 90° clockwise.
④	 Flip Horizontal: Use to make image mirror left and right.
⑤	 Flip Vertical: Use to make image mirror up and down.
⑥	 Pan: Drag images





7	 Zoom: Combine the mouse wheel to zoom in/out the image.
8	 Reset.
9	 Length: Measure length.
10	 Angle: Measure angle.
11	 Draw: Draw a curve.
12	 Line: Draw a straight line.
13	 Rectangle: Place rectangle.
14	 Ellipse: Place ellipse.
15	 Memo: Make a memo.
16	 Magnify: Local zoom
17	 Clear Overlayers



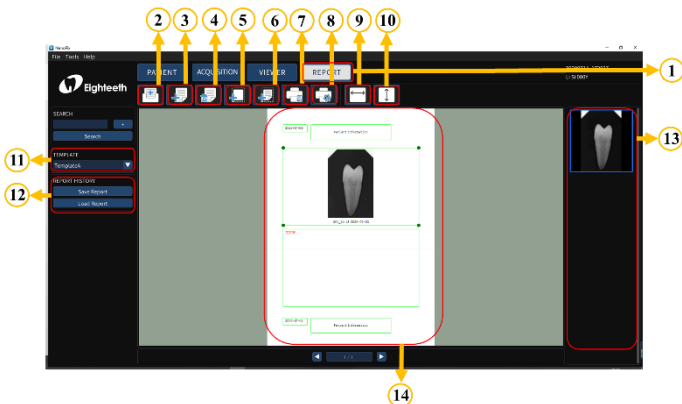

18	 Capture: Screenshot
19	 Grid.
20	IMAGE PROCESSING: use to process the acquired image data, include Endodontic, Periodontic, Restorative, Smart Contrast, Smart Sharpen, Smooth, Inverse, Colorize, and Reset.
21	BRIGHTNESS & CONTRAST: Manual, Auto and Reset.
22	LAYOUT: image layout, use to configure the image display.
23	X-ray image list: Double-click the X-ray image in the list to display it in the display area.
24	The display area of the oral X-ray image.

5.7 Oral Diagnostic Report Menu

The main page of Oral Diagnostic Report Menu



①	Report: Click it and enter the Oral Diagnostic Report Menu interface.
②	 New report
③	 Add page
④	 Delete page
⑤	 Add image box
⑥	 Add text box

7	 Print
8	 Print Setting
9	 Fit horizontal
10	 Fit vertical
11	TEMPLATE: Use to select a template for generating a medical record report.
12	REPORT HISTORY: Use to save the generated report and import the existing report.
13	X-ray image list
14	The display area of the report.

6. Operating Instructions

6.1 Acquiring Oral X-ray Image

1. Open NanoPix software.

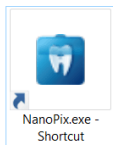

2. Click **PATIENT**, create a new medical record or select an existing medical record.

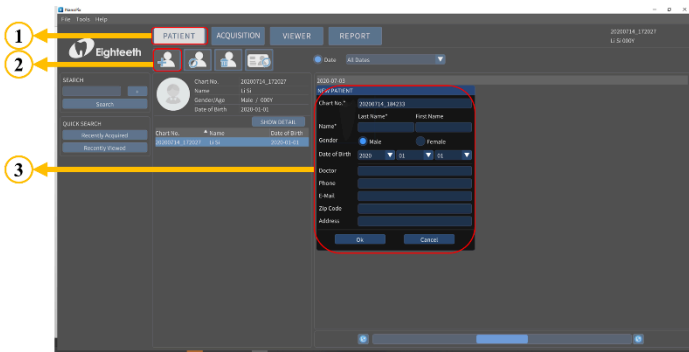

3. Click **ACQUISITION**, enter the oral X-ray image acquisition interface, and make sure the sensor is connected successfully (the  is ready).

6 Operating Instructions

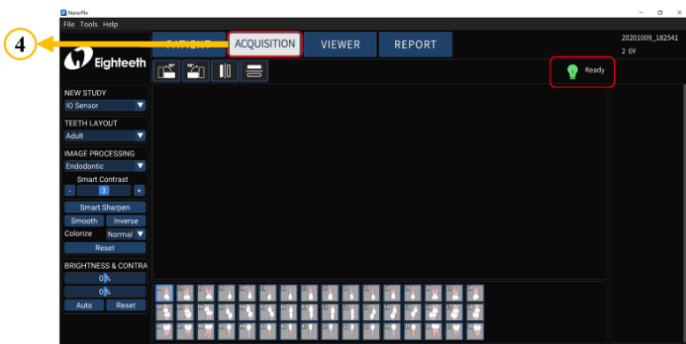

4. Make sure that the **NEW STUDY** is **IO Sensor** , and

determine the patient's **TEETH LAYOUT**

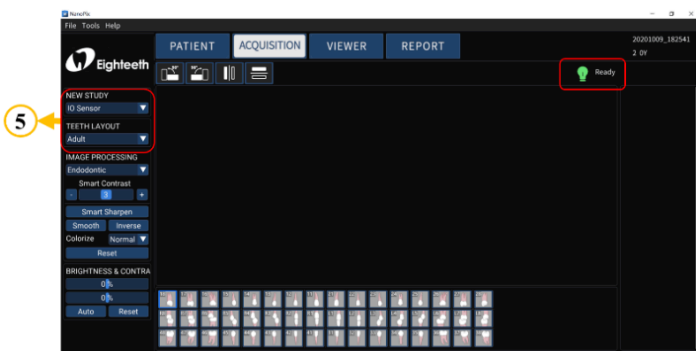
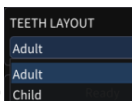

5. Use the handheld bracket to fix the sensor and a Disposable Sleeve to cover the sensor and handheld bracket and then place it in the mouth for imaging. For specific operations, please refer to **Chapter 4.8**.

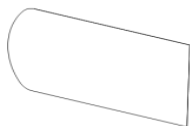

Handheld Bracket A

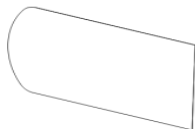
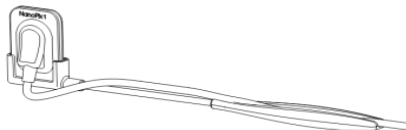

Handheld Bracket B

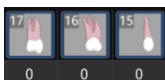

6. Click **(Optional)**, place the transmitter of the X-ray generator directly on the receiving surface of the sensor (ensure the receptor of the sensor can efficiently receive X-rays) and Press the exposure button to complete the collection, the interface displays the acquired X-ray image (**Figure A is only for illustration, this product does not include this part**).

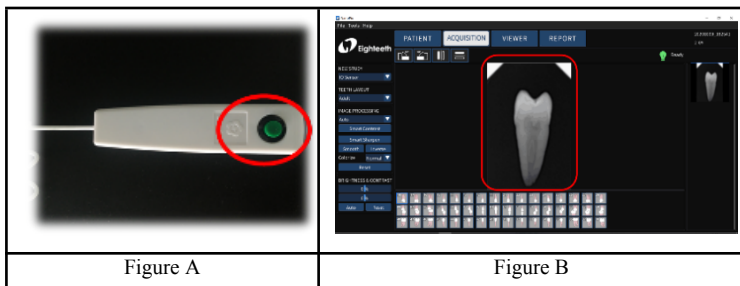

7. Checks the image quality, if it is not good, adjust the X-ray transmitter parameters (refer to chapter 7), repeat step 5-6.



WARNING

Please read the following warning carefully before using:

1. Before starting the experiment, please keep the sensor receiving board clean and wrap it with a disposable sleeve before putting it in the patient's mouth.
2. Before step 6, make sure that the X-ray transmitter is turned on and the sensor USB terminal is connected to the computer.
3. Before step 6, set the exposure time of the X-ray transmitter according to the actual needs.

6.2 Importing Existing Oral X-ray Images

1. Open NanoPix software.

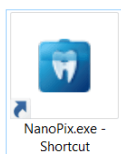

2. Click **PATIENT**, create a new medical record or select an existing medical record.

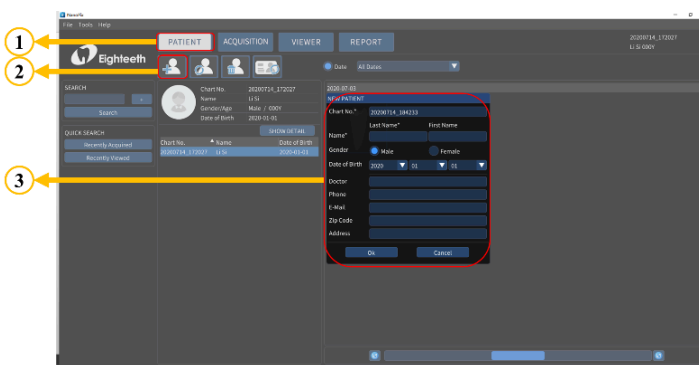

3. Click **ACQUISITION**, enter the oral X-ray image acquisition interface.

6 Operating Instructions

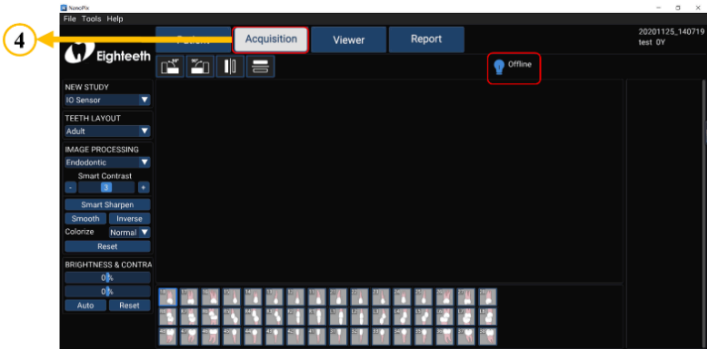

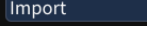
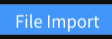
4. Make sure that the **NEW STUDY** is **Import** , and click  to import existing X-ray images (*jpeg, png, bmp, jpg, and dcm* file).

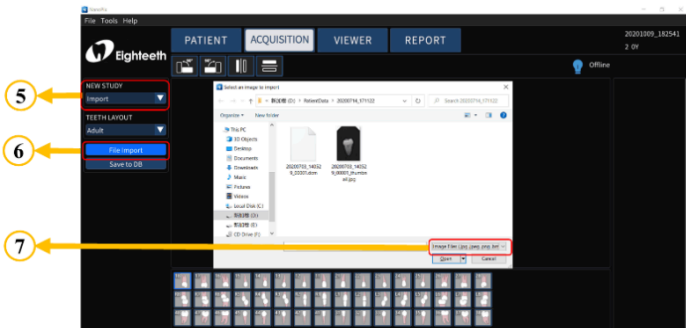

5. Save X-ray images to the database.

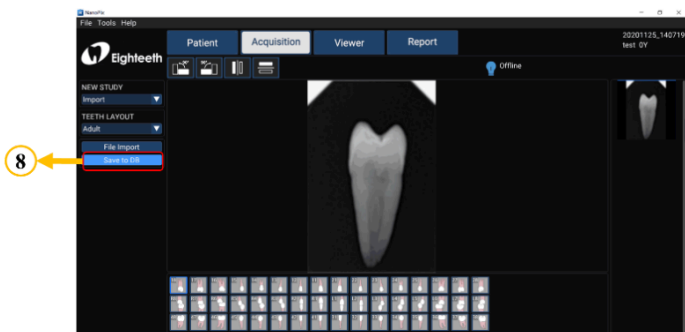

WARNING

Please read the following warning carefully before using:

Make sure to save the X-ray image to the database after finishing step 4. In other words, make sure to do step 5.

6.3 Image Quality Optimization

The image quality optimization currently supported by **NanoPix** includes **IMAGE PROCESSING**(Endodontic, Periodontic, Restorative), **Smart Sharpen**, **Smooth**, **Inverse**, **Colorize**, **Reset**, **BRIGHTNESS&CONTRA**(Manual, Auto, Reset). The

user can optimize the acquired X-ray image in the **VIEW**

VIEWER

interface.

6 Operating Instructions

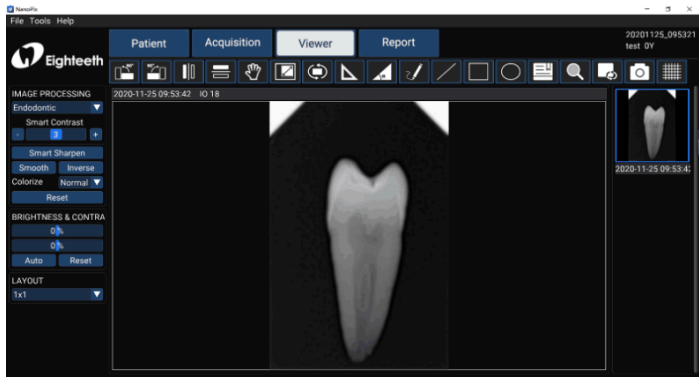

WARNING

Please read the following warning carefully before using:

Besides the optimization of the software, the image quality is also related to the **Dose / Exposure** time. The user can manually adjust the corresponding parameters according to experience or reference manual.

6.4 Report Generation

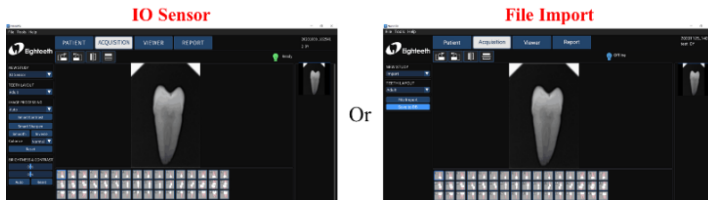

1. Obtain oral X-ray image data according to Section 6.1 or Section 6.2, and save the X-ray image to the database.

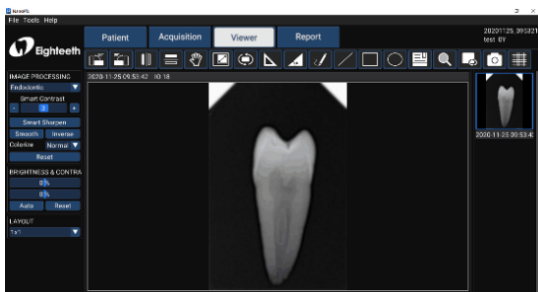

2. Optimize the acquired X-ray images according to section 6.3 (optional).

6 Operating Instructions



3. Click the **report**  to enter the oral diagnostic report interface, select the report **template** ; Select the picture frame and double-click the right X-ray image to fill the image box; Double-click the text box and input the patient's diagnosis results.

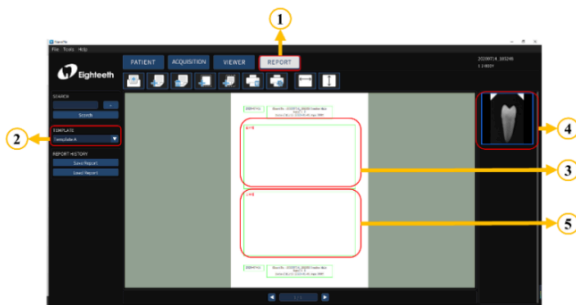

4. According to the actual needs, use the upper toolbar to edit the report, including creating a new report, adding a page, deleting a page, adding an image box, adding text box (optional); Finally, save and print the report.

6 Operating Instructions



7. Recommended X-ray Source Parameters and Exposure Time

7.1 Compatibility with radiographic generators

The NanoPix series sensor is generally compatible with any dental X-ray unit and generator capable of supplying the required range of exposure times and doses.

Follow the instructions of the X-ray generator to set the desired dose range.

The radiation of X-ray tubes is controlled by the settings of:

- Exposure time (msec) or pulses
- Voltage (kV or kVp)
- Current (mA)

Some controls allow for the modification of all of the above, some have fixed settings for current and voltage.

Distance of X-ray Source to Sensor

There is a correlation between the distance of the X-ray source to the sensor and the dose received by the NanoPix sensor. The radiation that reaches the sensor decreases with the square of the distance. If you double this distance, you receive only 1/4 of the radiation.

7.2 Recommendation

Protocol		Patient	X-Ray machine	Exposure time
Maxilla	Incisors	Child	70kV/8mA	0.032
		Adult	70kV/8mA	0.040
	Premolars and Canines	Child	70kV/8mA	0.040
		Adult	70kV/8mA	0.050
	Molars	Child	70kV/8mA	0.050
		Adult	70kV/8mA	0.063
Mandible	Incisors	Child	70kV/8mA	0.025
		Adult	70kV/8mA	0.032
	Premolars and Canines	Child	70kV/8mA	0.032
		Adult	70kV/8mA	0.040

7 Recommended X-ray Source Parameters and Exposure Time

	Molars	Child	70kV/8mA	0.040
		Adult	70kV/8mA	0.050

Note: X-ray sources: 70kV/8mA when using a 20cm SID

Important

Recommended exposure time can vary depending on the patient's body size, age, sex and thickness of the position to be photographed.

Please adjust exposure time according to patient.

exposure time	Dose (μGy)	60kVp 6mA	60kVp 2mA	65kVp 5mA
Patient		Adult	Adult	Adult
SID		28cm	28cm	28cm
Intra Oral X-ray Unit	No filter			
		Approximate exposure time(second)		
Incisor & Canine	300~500	0.12~0.2	0.1~0.2	0.18~0.28
Molar	400~600	0.16~0.25	0.15~0.25	0.24~0.34

*SID: Source to X-ray imaging sensor receptor distance.

*Make sure whether your exposure source is **AC** or **DC**.

*If your exposure source cannot trigger the sensor, you can modify the exposure trigger threshold through software: **Tools** **Settings** **Acquisition** **Trigger setting**. The operation steps could refer to chapter 5.3. In our test, the exposure source parameter used is **60kV 1mA**, and its corresponding threshold is **50uGy**; if the exposure source you use is **higher** than this parameter, you can set the threshold to **100uGy** or **200uGy** to give it a try; if the exposure source used is **lower** than this parameter, you can set the threshold to **20uGy** or **5uGy**. The advantage of this operation is that it can Improve image quality.



NOTE

For larger body types: increase the exposure time(or Source current) by 25%

For children(5~21age): reduce the exposure time(or Source current) by 20%

For edentulous patients: reduce the exposure time(or Source current) by 20%.



WARNING

1. Since the X-ray exposure condition can be changed depending on the age, gender, and bone density of the patient, in the case of Pediatric, X-ray exposure

condition can be changed by the expert's judgment.

2. For X-ray protection: All X-ray equipment for Dental Intra-oral Radiography used with NanoPix1/ NanoPix1.5/NanoPix2 must conform to IEC 60601-2-65:2012. The rules for dental radiography still apply to digital X-ray systems. Please continue to use protection for your patients. As a clinician, clear the immediate area when exposing the sensor.

8. Maintenance

8.1 Foreword

For hygiene and sanitary safety purpose, the sensor must be cleaned and disinfected even if the disposable sleeve is used. The silicone protective cover and handheld bracket can be steam sterilized, and they should be cleaned, disinfected and sterilized before each usage to prevent any contamination. This concerns the first use as well as the subsequent uses. Comply with your national guidelines, standards and requirements for cleaning, disinfection and sterilization.

Reprocessing procedures have only limited implications to this dental instrument. The limitation of the numbers of reprocessing procedures is therefore determined by the function / wear of the device. From the processing side there is no maximum number of allowable reprocessing. The device should no longer be reused in case of signs of material degradation.





In case of damage, the device should be reprocessed before sending back to the manufacturer for repair.

8.2 General recommendations

- The user is responsible for the sterility of the product for the first cycle and each further usage as well as for the usage of damaged or dirty instruments, where applicable after sterility.
- For your own safety, please wear personal protective equipment (gloves, safety glasses, etc.).
- Use only a disinfecting solution which is approved for its efficacy (VAH/DGHM-listing, CE marking, and FDA approval) and in accordance with the DFU of the disinfecting solution manufacturer.
- The water quality has to be convenient to the local regulations especially for the last rinsing step or with a washer-disinfector.
- Thoroughly clean and wash the sterilizable components before autoclaving.
- Do not use bleach or chloride disinfectant materials.

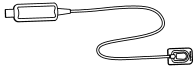
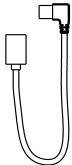
8.3 Disinfection components

Disinfection components

<p>Sensor</p> 	<p>USB Extension Cable</p> 	<p>Sensor Mounting Bracket</p> 
 <p>WARNING</p> <p>Before first use, after each use and whenever there is a risk of contamination, disinfect the above components.</p>		
<p>Reprocessing Instructions</p>		
<p>Preparation before cleaning:</p> <p>Immediately after using, remove the used disposable sleeve. Disconnect all plug connections. Put the sensor and USB Extension Cable in container for transportation.</p>		
 <p>WARNING</p> <p>Make sure that used sleeves are disposed of as infected waste which is potentially biologically hazardous.</p>		
<p>Transportation:</p> <p>Safe storage and transportation to the reprocessing area to avoid any damage and contamination to the environment.</p>		
<p>Cleaning</p> <p>Wipe the surface of the sensor, USB extension cable and mounting bracket surface with a gauze soaked in isopropyl alcohol (70%), until the components are free of visible soils. Repeat this step with a new gauze soaked in isopropyl alcohol (70%), if necessary.</p> <p>Dry the components with compressed air.</p> <p>Disinfection</p> <p>Wipe off the sensor, USB extension cable and mounting bracket surface with a</p>		

gauze soaked in isopropyl alcohol (70%) to disinfect them completely and thoroughly for at least 1 minute.

Remove any chemical residues by wiping the components clean and dry with a sterile cloth.

**NOTE**

1. Do not use disinfectants other than isopropyl alcohol (70%) for disinfection.
2. Make sure no liquid penetrates the sensor through the USB cable or connectors, otherwise, it will damage the internal parts.
3. When cleaning the cable, hold the sensor with one hand and wipe with the other hand from the sensor receiving board to the sensor USB connector. Do not pull on the insulation of the cable.

**WARNING**

1. Do not disinfect the sensor in an autoclave or other sterilization container.
2. Do not soak or immerse any part of the sensor in liquid.

Storage:

Store the components in a clean and dry place for the next treatment.

8.4 Autoclavable Components

Autoclavable Components

Silicone Protective Cover

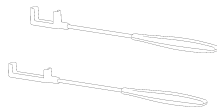

Handheld Bracket (purchased separately)

**WARNING**

1. Only the above components can be autoclaved.
2. Before first use and after each use, sterilize the above components.

Reprocessing Instructions

Preparation at the Point of Use:

1. Disconnect the silicone protective cover and handheld bracket before cleaning. Remove gross contaminations from the components with code water (<math><40^{\circ}\text{C}</math>) immediately after use. Don't use a fixating detergent or hot water (>math>>40^{\circ}\text{C}</math>) as this can cause the fixation of residuals which may influence the result of the reprocessing process.
2. Store the instruments in a humid surrounding.



WARNING

Do not submerge the components or wipe them with any of the following functional water (acidic electrolyzed water, strong alkaline solution, or ozone water), medical agents (glutaral, etc.), or any other special types of water or commercial cleaning liquids. Such liquids may result in metal corrosion and adhesion of the residual medical agents to the components.

Transportation:

Safe storage and transportation to the reprocessing area to avoid any damage and contamination to the environment.

Preparation for Decontamination:

The devices must be reprocessed in a disassembled state.



WARNING

Observe suitable personal protective measures.

Pre-Cleaning:

Do a manual pre-cleaning, until the components are visually clean. Submerge the components in a cleaning solution. Clean the surfaces with a soft bristol brush.

Cleaning:

Regarding cleaning/disinfection, rinsing and drying, it is to distinguish between manual and automated reprocessing methods. Preference is to be given to automated reprocessing methods, especially due to the better standardizing potential and industrial safety.

Automated Cleaning:

Carefully put the components into the washer-disinfector on a tray and set the parameters as follows, then start the program:

- 4 min pre-washing with cold water (<40°C);
- emptying
- 5 min washing with a mild alkaline cleaner at 55°C;
- emptying
- 3 min neutralising with warm water (>40°C);
- emptying
- 5 min intermediate rinsing with warm water (>40°C);
- emptying

The automated cleaning processes have been validated by using 0.5% neodisher MediClean forte (Dr. Weigert).

Note Acc. to EN ISO 17664 no manual reprocessing methods are required for these devices. If a manual reprocessing method has to be used, please validate it prior to use.



WARNING

1. Use only approved washer-disinfectors according to EN ISO 15883, maintain and calibrate it regularly.
2. Follow instructions and observe concentrations given by the manufacturer (see general recommendations).

Disinfection:

Automated Thermal Disinfection in washer/disinfector under consideration of national requirements in regards to A0 value (see EN ISO 15883).

A disinfection cycle of 5 min disinfection at 93°C has been validated for the device to achieve an A0 value of 3000.

After manual cleaning, the instruments should be automated disinfected or sterilized immediately. A manual disinfection is not recommended.

Drying:

Automated Drying:

Drying the components through drying cycle of washer/disinfector. If needed, additional manual drying can be performed through lint free towel. Insufflate cavities of instruments by using sterile compressed air.

Functional Testing, Maintenance:

Visual inspection for cleanliness of the components and reassembling. Functional testing according to instructions of use. If necessary, perform reprocessing process again until component is visibly clean.

Packaging:

Pack the instruments in an appropriate packaging material for sterilization.

**WARNING**

- Check the validity period of pouch given by the manufacturer to determine the shelf life.
- Use pouches which resist to a temperature up to 141°C and in accordance with EN ISO 11607.

Sterilization:

Sterilization of components by applying a fractionated pre-vacuum steam sterilization process (according to EN 285/EN 13060/EN ISO 17665) under consideration of the respective country requirements.

Minimum requirements: 3 min at 134 °C (in EU: 5 min at 134°C)

Maximum sterilization temperature: 137°C

Drying time: at least 8min.

**WARNING**

- Use only approved autoclave devices according to EN 13060 or EN 285.
- Use a validated sterilization procedure according to EN ISO 17665.
- Respect the maintenance procedure of the autoclave device given by the manufacturer.
- Use only this recommended sterilization procedure.

- Control the efficiency (packaging integrity, no humidity, color change of sterilization indicators, physicochemical integrators, digital records of cycles parameters).
- Waiting for cooling before touching.

Storage:

Storage of sterilized components in a dry, clean and dust free environment at modest temperatures, refer to label and instructions for use.

**WARNING**

- Sterility cannot be guaranteed if packaging is open, damaged or wet.
- Check the packaging before using it (packaging integrity, no humidity and validity period).

Reprocessing validation study information:

The above-mentioned reprocessing process (cleaning, disinfection, sterilization) has been successfully validated. Refer to test reports: RDS2020D0097 001 and RDS2020E0091 001.

**NOTE**

The instructions provided above have been validated by the manufacturer of the medical device as being capable of preparing a medical device for reuse. It remains the responsibility of the processor to ensure that the processing, as actually performed using equipment, materials and personnel in the processing facility, achieves the desired result. This requires verification and/or validation and routine monitoring of the process. Likewise, any deviation by the processor from the instructions provided should be properly evaluated for effectiveness and potential adverse consequences.

8.5 Sensor inspection

For the safety of patients, operators or other third parties, and to maintain the good

8 Maintenance

performance and reliability of the device, always inspect the sensor and cable for physical damage prior to each use, and conduct regular inspections at least once a year to check the resolution, linearity range and correction, if necessary, contact us or local dealer for the regular inspection.

9. Troubleshooting

When a problem or malfunction occurs, please check the machine with the table below before contacting the dealer to quickly eliminate common problems or malfunctions. If the problem or malfunction is not solved, please contact the dealer.

Problem or malfunction	Reasons & Solutions
After triggering X-ray, no image is displayed	Check whether the connection between the sensor and the computer is normal.
	Check if the sensor's X-ray receiver is facing the X-ray generator.
	In the software setting interface, try to set other exposure thresholds, the operation could refer to section 5.3.
	Close and reopen the software.
	Unplug the sensor and plug it in again.
The X-ray image is dim and textured	Exposure time is too short, increase exposure time.
	The selected acquisition mode does not correspond to the X-ray dose.
	The voltage of the high voltage generator is too low (less than 60kVrms), check the high voltage generator.
	The distance between the high voltage generator and the patient is too far to match the selected dose.
	Check the contrast and brightness settings of the computer to ensure that there is no problem with the screen display.
The X-ray image is too dark	The exposure time is too long, shorten the exposure time.
	The selected acquisition mode does not correspond to an X-ray dose.
	Check the contrast and brightness settings of the computer to ensure that there is no problem with the screen display.
The X-ray image is blurred	The patient moves during exposure.
	The head of the generator is unstable.

9 Troubleshooting

The image is white	The receiver of the sensor is not in the X-ray direction.
	Insufficient X-ray dose.
	The sensor is not connected or improperly connected.
	Check the high-voltage generator to ensure that it emits X-rays.

10. Technical Data

Manufacturer	Changzhou Sifary Medical Technology Co., Ltd.
Model	NanoPix1/ NanoPix1.5/NanoPix2
Dimensions	19.6cm x 14.4cm x 3.4cm±1cm(Package)
Weight	0.4kg ± 10%
Effective imaging area	NanoPix1: 20x30mm ²
	NanoPix1.5: 24x 33mm ²
	NanoPix2: 26x36mm ²
Power	2W Max
Sensor technology	CMOS Csi
Pixel size	20um
Resolution	Theoretical: 25 lp/mm
	Measured: > 12 lp/mm
X-ray energy range	60-70kV
Data interface	USB2.0
Electrical safety class	Depend on the computer terminal that the sensor is connected to.
Protection against liquid / particular matter	IP68 (Intraoral part of sensor)
	IPX8 (USB cables)
Anti-defibrillation application part	No
AP/APG type equipment	Non-AP/APG type equipment
Operating conditions	Use: in enclosed spaces
	Ambient temperature: 10°C ~ 35 °C
	Relative humidity: 20% ~ 90%
	Operating altitude < 3000m above sea level
Transport and storage conditions	Ambient temperature: -20 °C ~ 55 °C
	Relative humidity: 20% ~ 80%, no condensation
	Atmospheric pressure: 70kPa~106kPa

11. EMC Tables

Guidance and manufacturer's declaration – electromagnetic emissions			
The NanoPix1/NanoPix1.5/NanoPix2 is intended for use in the electromagnetic environment specified below. The customer or the user of the NanoPix1/NanoPix1.5/NanoPix2 should assure that it is used in such an environment.			
Emissions test	Compliance	Electromagnetic environment - guidance	
RF emissions CISPR 11	Group 1	The NanoPix1/NanoPix1.5/NanoPix2 uses RF energy only for its internal function. Therefore, its RF emissions are very low and are not likely to cause any interference in nearby electronic equipment.	
RF emissions CISPR 11	Class A	The NanoPix1/NanoPix1.5/NanoPix2 is suitable for use in all establishments, including domestic establishments and those directly connected to the public low-voltage power supply network that supplies buildings used for domestic purposes.	
Harmonic emissions IEC61000-3-2	Class A		
Voltage fluctuations/flicker emissions IEC 61000-3-3	NA(*)		
(*)NanoPix1/ NanoPix1.5/NanoPix2 is not intended to connect to the PUBLIC MAINS NETWORK, and this test is not applicable in this environment. Computers used with the NanoPix1/NanoPix2 sensor must meet this rating.			

Guidance and manufacturer's declaration – electromagnetic immunity			
The NanoPix1/NanoPix1.5/NanoPix2 is intended for use in the electromagnetic environment specified below. The customer or the user of the NanoPix1/NanoPix1.5/NanoPix2 should assure that it is used in such an environment.			
Immunity test	IEC 60601 test level	Compliance level	Electromagnetic environment - guidance
Electrostatic discharge (ESD) IEC 61000-4-2	+/- 8 kV contact +/- 2 kV, +/- 4 kV, +/- 8 kV, +/- 15 kV air	+/- 8 kV contact +/- 2 kV, +/- 4 kV, +/- 8 kV, +/- 15 kV air	Floors should be wood, concrete or ceramic tile. If floors are covered with synthetic material, the relative humidity should be at least 30 %.

11 EMC Tables

Electrical fast transients/bursts IEC 61000-4-4	±2kV 100kHz repetition frequency	±2kV 100kHz repetition frequency	Mains power quality should be that of a typical commercial or hospital environment.
Surge IEC 61000-4-5	Line to line: ±0.5kV, ±1kV Line to earth: ±0.5kV, ±1kV, ±2kV	Line to line: ±0.5kV, ±1kV Line to earth: ±0.5kV, ±1kV, ±2kV	Mains power quality should be that of a typical commercial or hospital environment.
Voltage dips IEC 61000-4-11	0% UT; 0.5 cycle at 0°, 45°, 90°, 135°, 180°, 225°, 270°, and 315° 0% UT; 1 cycle and 70% UT; 25/30 cycles sine phase at 0°	0% UT; 0.5 cycle at 0°, 45°, 90°, 135°, 180°, 225°, 270°, and 315° 0% UT; 1 cycle and 70% UT; 25/30 cycles sine phase at 0°	Mains power quality should be that of a typical commercial or hospital environment. If the user of devices require continued operation during power mains interruptions, it is recommended that devices be powered from an uninterruptible power supply or a battery
Voltage interruptions IEC 61000-4-11	0% UT; 250/300 cycle	0% UT; 250/300 cycle	
Rated Power frequency magnetic field IEC 61000-4-8	30 A/m 50Hz or 60Hz	30 A/m 50Hz or 60Hz	Power frequency magnetic field should be at levels characteristic of a typical location in a typical commercial or hospital environment.
Note: UT: rated voltage(s); E.g. 25/30 cycles means 25 cycles at 50Hz or 30 cycles at 60Hz			

Guidance and manufacturer's declaration – electromagnetic immunity

The **NanoPix1/NanoPix1.5/NanoPix2** is intended for use in the electromagnetic environment specified below. The customer or the user of the **NanoPix1/NanoPix1.5/NanoPix2** should assure that it is used in such an environment.

Immunity test	IEC 60601 test level	Compliance level	Electromagnetic environment - guidance
<p>Conducted dis-turbances induced by RF fields IEC 61000-4-6</p> <p>Radiated RF EM fields IEC 61000-4-3</p>	<p>3 V 0.15 MHz – 80 MHz, 6 V in ISM bands be-tween 0.15 MHz and 80 MHz, 80 % AM at 1 kHz</p> <p>3 V/m, 80 MHz – 2,7 GHz, 80 % AM at 1 kHz</p> <p>See the RF wireless communication equipment table in "Recommended minimum separation distances"</p>	<p>3 V</p> <p>3V/m</p>	<p>Portable and mobile RF communications equipment should be used no closer to any part of the NanoPix1/NanoPix1.5/NanoPix2, including cables, than the recommended separation distance calculated from the equation applicable to the frequency of the transmitter.</p> <p>Recommended minimum separation distances See the RF wireless communication equipment table in "Recommended minimum separation distances"</p>
<p>Proximity fields from RF wireless communication equipment IEC 61000-4-3</p>		<p>Complies</p>	

Recommended minimum separation distances

Nowadays, many RF wireless equipments have being used in various healthcare locations where medical equipment and/or systems are used. When they are used in close proximity to medical equipment and/or systems, the medical equipment and/or systems' basic safety and essential performance may be affected. The **NanoPix1/NanoPix1.5/NanoPix2** has been tested with the immunity test level in the below table and meet the related requirements of IEC 60601-1-2:2014. The customer and/or user should help keep a minimum distance between RF wireless communications equipment and the **NanoPix1/NanoPix1.5/NanoPix2** as recommended below.

Test frequency (MHz)	Band (MHz)	Service	Modulation	Maximum power (W)	Distance (m)	Immunity test level (V/m)
385	380-390	TETRA 400	Pulse modulation 18Hz	1.8	0.3	27
450	430-470	GMRS 460 FRS 460	FM ± 5 kHz deviation 1 kHz sine	2	0.3	28
710	704-787	LTE Band 13, 17	Pulse modulation 217Hz	0.2	0.3	9
745						
780						
810	800-960	GSM 800/900, TETRA 800, iDEN 820, CDMA 850, LTE Band 5	Pulse modulation 18Hz	2	0.3	28
870						
930						
1720	1700-1990	GSM 1800; CDMA 1900; GSM 1900; DECT; LTE Band 1,3,4,25; UMTS	Pulse modulation 217Hz	2	0.3	28
1845						
1970						
2450	2400-2570	Bluetooth, WLAN, 802.11 b/g/n, RFID 2450, LTE Band 7	Pulse modulation 217Hz	2	0.3	28
5240	5100-5800	WLAN 802.11 a/n	Pulse modulation 217Hz	0.2	0.3	9
5500						
5785						



WARNING

- Use of accessories and cables other than those specified or provided by the manufacturer of **NanoPix1/NanoPix1.5/NanoPix2** could result in increased

electromagnetic emissions or decreased electromagnetic immunity of **NanoPix1/NanoPix1.5/NanoPix2** and result in improper operation.

Cable information:

Cable Name	Cable Length(m)	Shielded or not	Remark
Communication line	2.80	Yes	/
USB extension cable	0.13	Yes	/

2. Use of **NanoPix1/NanoPix1.5/NanoPix2** adjacent to or stacked with other equipment should be avoided because it could result in improper operation. If such use is necessary, **NanoPix1/NanoPix1.5/NanoPix2** and the other equipment should be observed to verify that they are operating normally.

12. Statement

Expected Service Life

The expected service life of *NanoPix* series products is 5 years.

Warranty

MANUFACTURER hereby warrants *NanoPix* series products against defects in material and the workmanship under normal usage and service for a period of 24 months from the date of installation.

If the Buyer promptly notifies MANUFACTURER or the Seller regarding any parts that fail to perform as specified under normal usage during the Warranty Period and MANUFACTURER determines that such failure resulted from a defect in materials or workmanship during the Warranty Period, then MANUFACTURER, at its option, shall repair, rebuild or adjust the affected parts.

Maintenance

MANUFACTURE will provide circuit diagrams, component part lists, descriptions, calibration instructions to assist to SERVICE PERSONNEL in parts repair.

Disposal

The package should be recycled. Metal parts of the device are disposed as scrap metal. Synthetic materials, electrical components, and printed circuit boards are disposed as electrical scrap. Please deal with them according to the local environmental protection laws and regulations.

Rights

All rights of modifying the product are reserved to the manufacturer without further notice. The pictures are only for reference. The final interpretation rights belong to CHANGZHOU SIFARY MEDICAL TECHNOLOGY CO., LTD. The industrial design, inner structure, etc, have claimed for several patents by SIFARY, any copy or fake product must take legal responsibilities.



Changzhou Sifary Medical Technology Co., Ltd.

Add: NO.99, Qingyang Road, Xuejia County, Xinbei District, Changzhou
City, 213000 Jiangsu, China

Tel: +86-0519-85962691

Fax: +86-0519-85962691

Email: info@sifary.com

Web: www.sifary.com

All rights reserved.